



GROUP 17

AXLE SHAFTS

INDEX

- AXLE SHAFTS 17-3
- DESCRIPTION 17-3
- REMOVAL AND REFITTING 17-5
- CONSTANT SPEED JOINTS 17-8
 - Disassembly of joint on gearbox side 17-8
 - Disassembly of joint on wheel side 17-8
- CHECKING AND ADJUSTMENT .. 17-9
- REFITTING THE JOINT ON THE WHEEL SIDE 17-9
- REFITTING THE JOINT ON THE GEARBOX SIDE 17-11

- TECHNICAL CHARACTERISTICS AND SPECIFICATIONS17-12
- GENERAL SPECIFICATIONS17-12
 - Fluids and lubricants17-12
- TIGHTENING TORQUES17-12
- SPECIFIC TOOLS17-12

For all parts not given here, refer to the corresponding Group in publication No. PA4655C1000000.

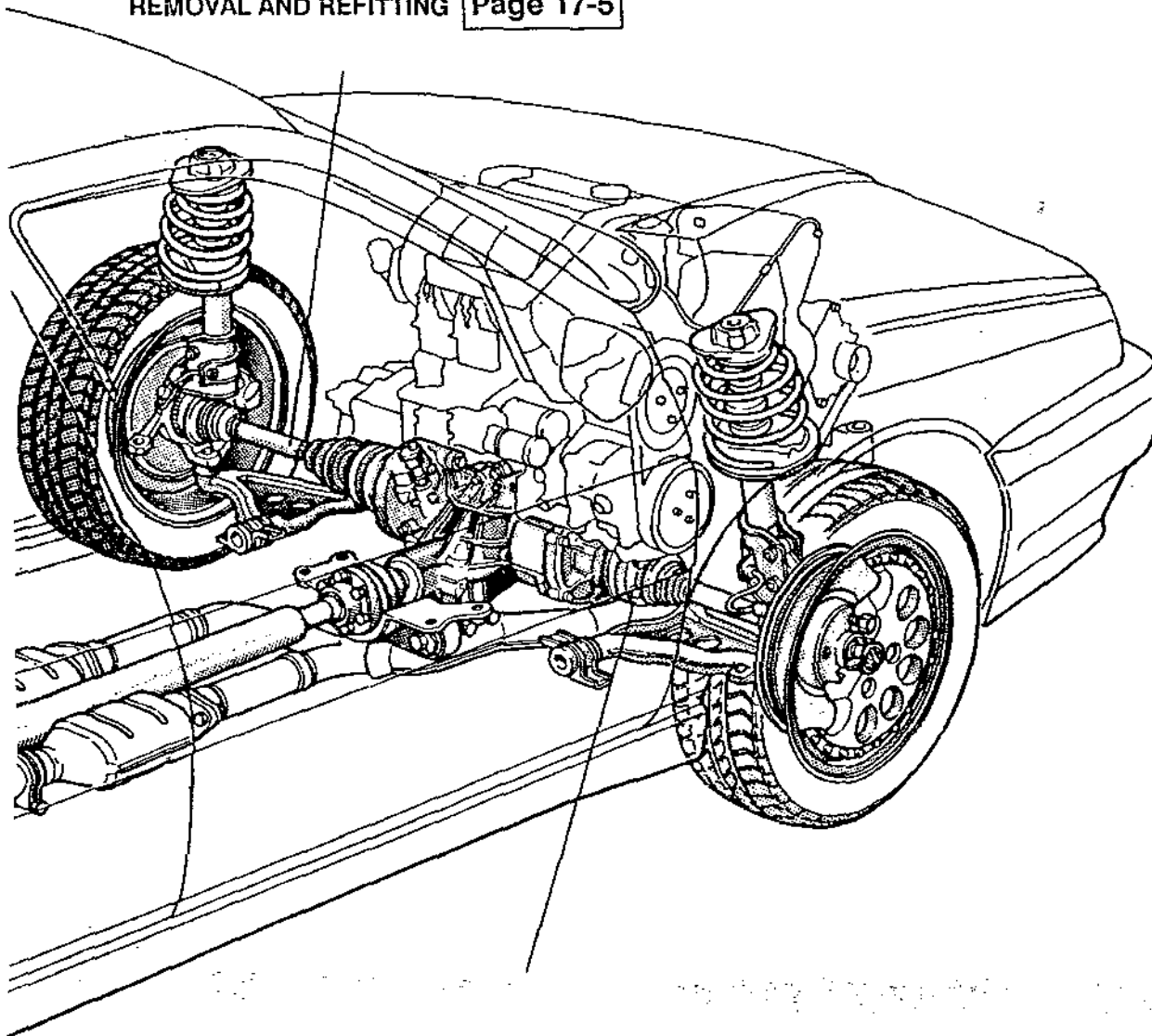
ILLUSTRATED INDEX**SHAFTS**DESCRIPTION **Page 17-3**REMOVAL AND REFITTING **Page 17-5**CONSTANT SPEED JOINTS **Page 17-8**DISASSEMBLY OF JOINT ON GEARBOX SIDE **Page 17-8**DISASSEMBLY OF JOINT ON WHEEL SIDE **Page 17-8**CHECKING AND ADJUSTMENT **Page 17-9**REFITTING THE JOINT ON THE WHEEL SIDE **Page 17-9**REFITTING THE JOINT ON THE GEARBOX SIDE **Page 17-11**

AXLE SHAFTS

DESCRIPTION

The axle shafts, constant speed joints and the inter-

mediate shaft form the assembly of the devices which transmits the movement from the gearbox to the drive wheels.

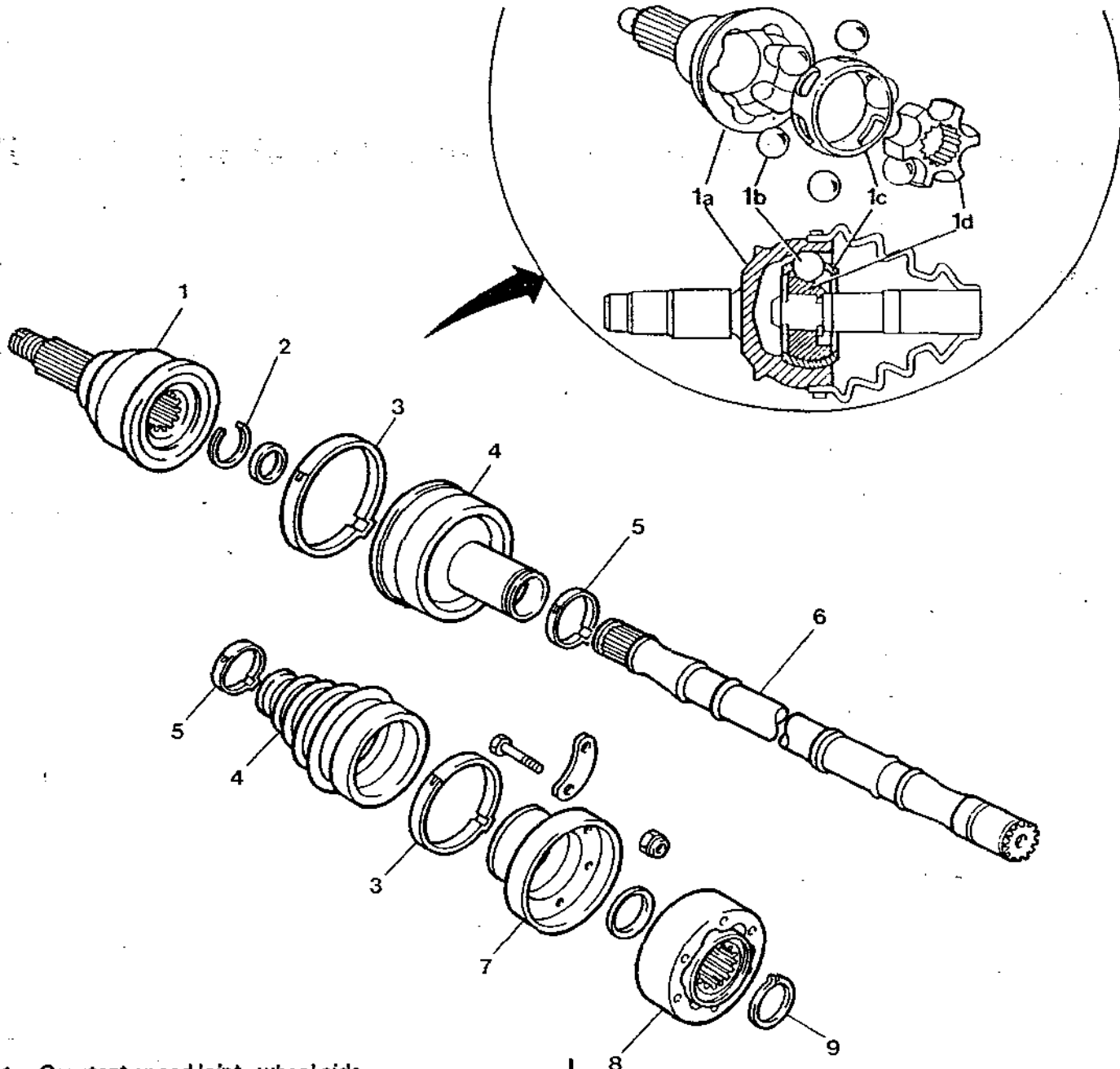

- 1. Constant speed joint - wheel side
- 2. Flexible ring
- 3. Retaining clamp
- 4. Cover
- 5. Retaining clamp

- 6. Axle shaft
- 7. Constant speed joint attachment flange
- 8. Constant speed joint - gearbox side
- 9. Flexible ring



The union of these devices, commonly called "transmission" when allied with the gearbox is composed of:

Right and left-hand axle shafts;

constant speed joints - gearbox and wheel sides;

intermediate shaft.

The high resistance steel axle shafts (6), have grooved ends in order to permit coupling with the constant speed joints (1) and (8). The seating for the flexible rings (2) and (9) is to be found on the constant speed joint and secures the joints themselves.

The constant speed joints are composed of an inner core (1d) called "drive", machined onto the input shaft, and by an outer shell (1a) called "driven", which forms the outgoing element of the shaft.

The inner core has six spherical grooves on its outer surface containing six balls (1b) kept in place by a cage (1c).

These balls are the parts which actually transmit the motion and are also located in other grooves on the inner surface of the shell.



REMOVAL AND REFITTING

1. Set the vehicle on a lift.
2. Lift the bonnet.
3. Disconnect and remove the battery.
4. Remove the front wheels.

**WARNING:**

Protect the areas around the engine compartment with soft material in order to avoid accidentally damaging the bodywork.

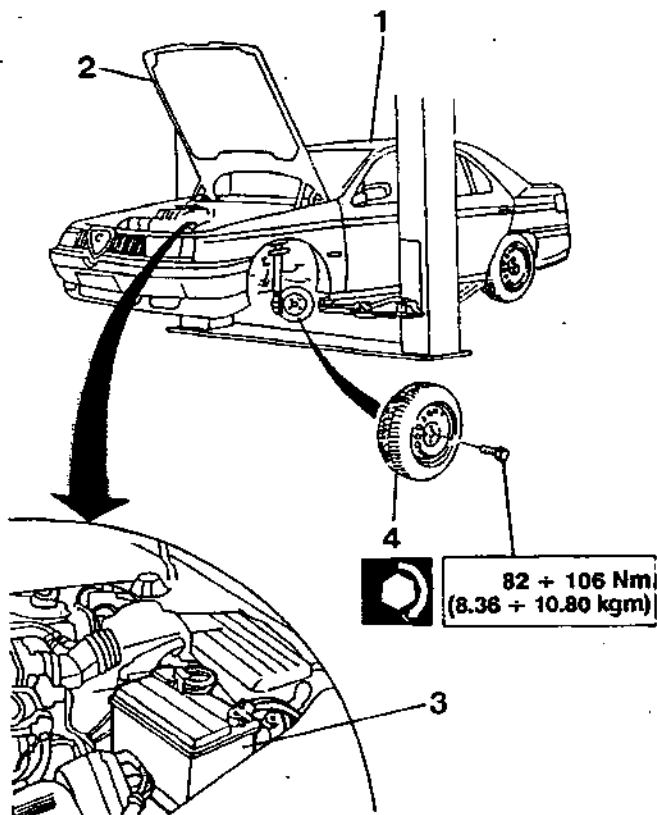

- Raise the vehicle.
1. Working through the left-hand wheelhousing, loosen the screws and remove the buttons securing the dustguard on the gearbox side.

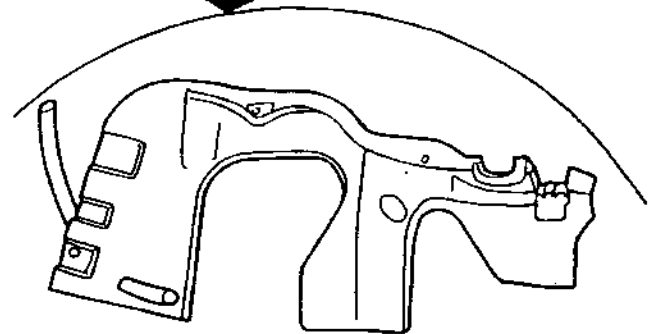
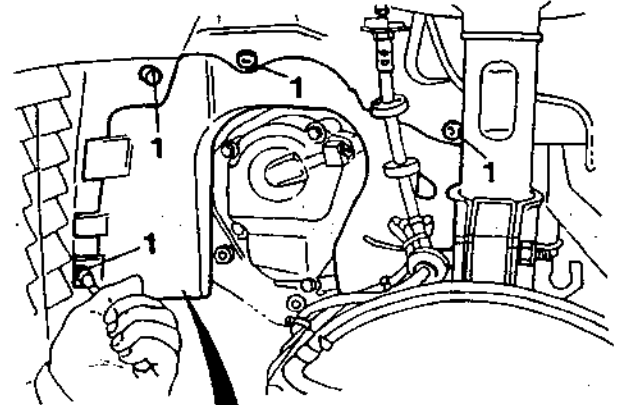

1. Disconnect the connector from the brake pad wear sensor.

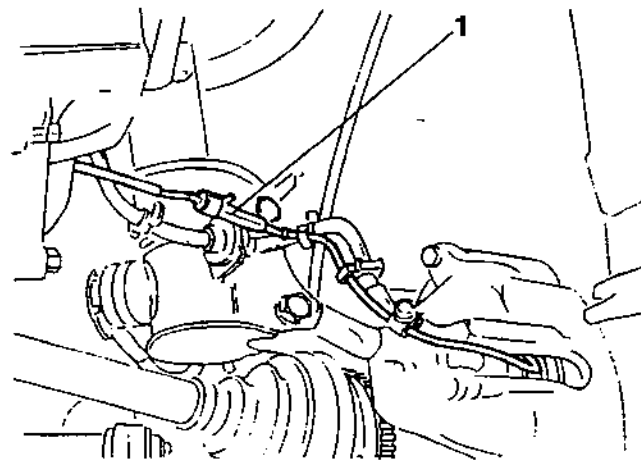



(only for vehicles equipped with controlled damping suspension):

- disconnect the connector from the controlled damping sensor.

2. (only for vehicles equipped with ABS):

- Loosen the screw securing the ABS system wiring support bracket and move it to one side and secure it to the suspension.

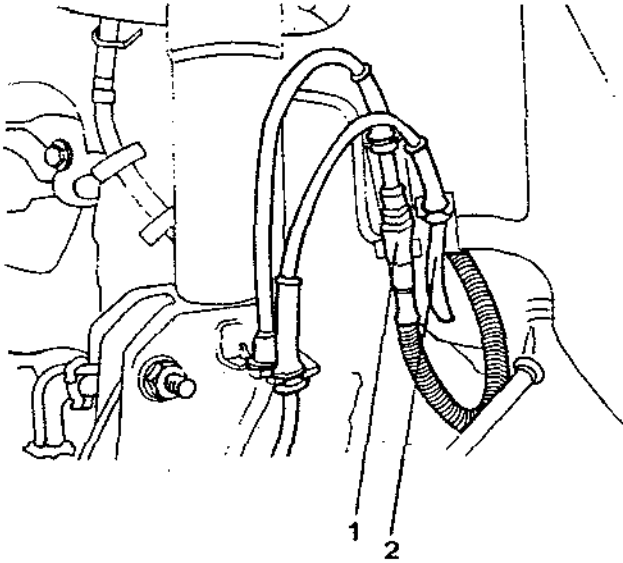

1. Loosen the screws and remove the plastic wheel-housing from the body.

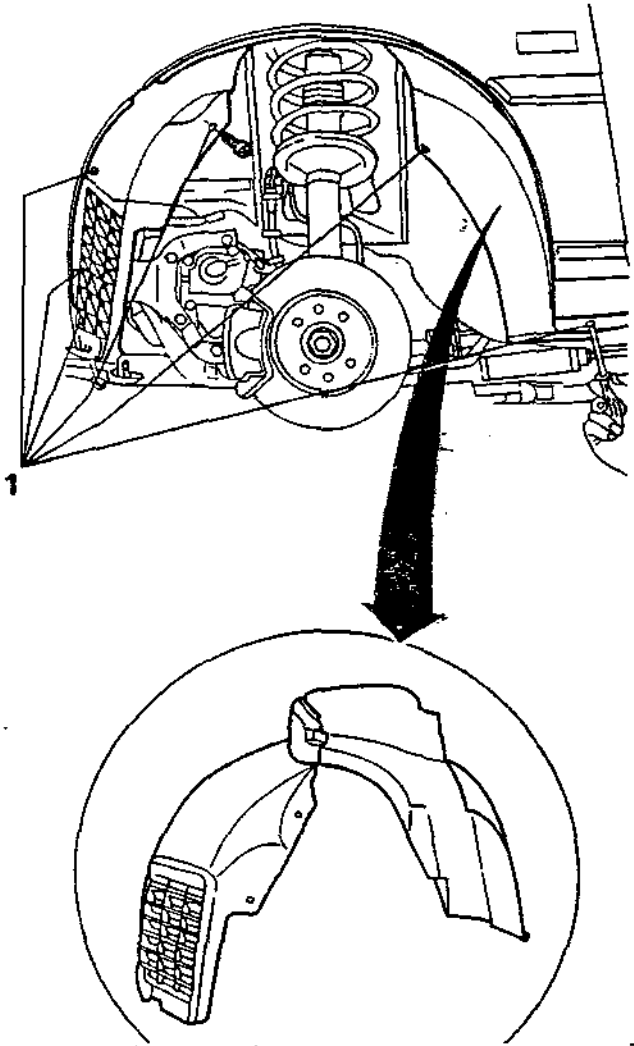



1. Unscrew the six bolts and disconnect the left-hand constant speed joint from the differential flange. Remove the three safety plates.
2. Remove the caulking and unscrew the nut securing the wheel hub to the axle shaft.



When refitting, caulk the new nut and tighten it to the correct torque.

3. Slide off the axle shaft and remove it.

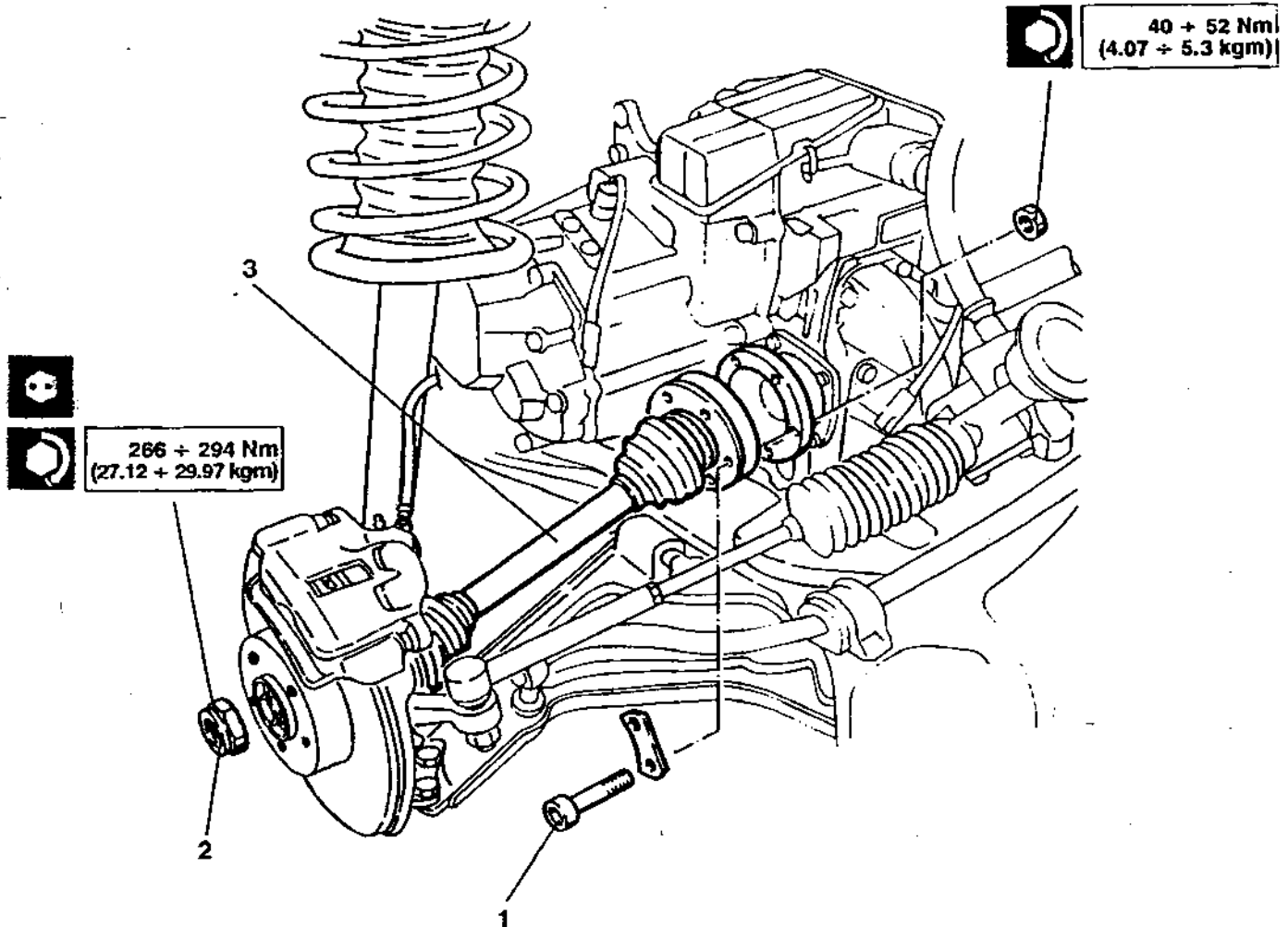

CONSTANT SPEED JOINTS

DISASSEMBLY OF JOINT ON GEARBOX SIDE

1. Remove the snap ring.
2. Remove the bellows retaining clamps.
3. Slide the constant speed joint off the axle shaft.
4. Pull off the protective boot.



WARNING:
Substitute the boot and clamps when re-fitting.

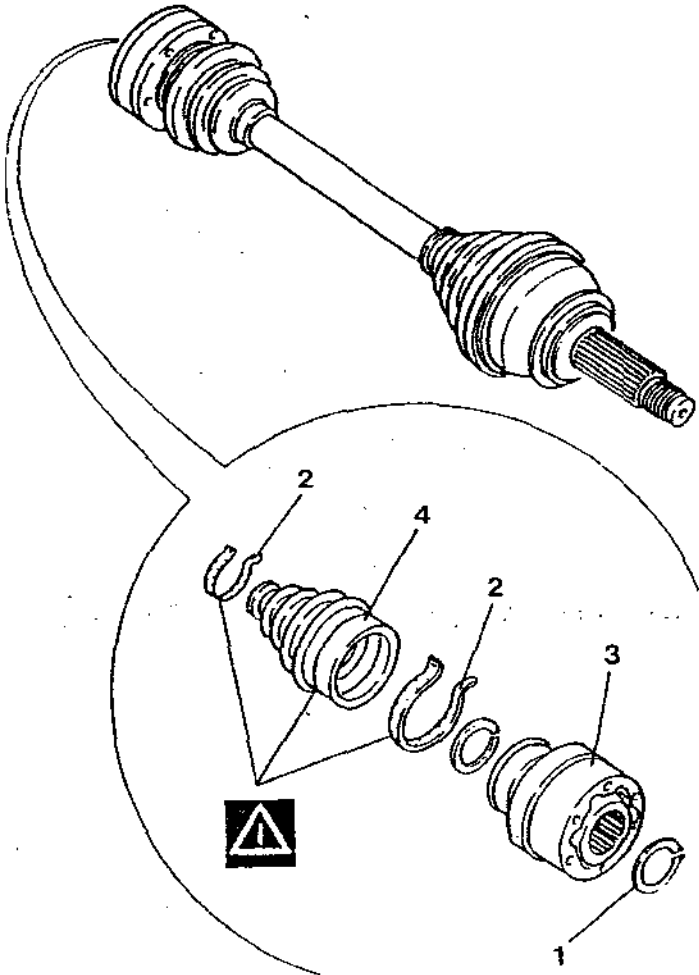

DISASSEMBLY OF JOINT ON WHEEL SIDE

Lock the axle shaft in a vice and proceed as follows:

1. Remove the clamp securing the protective boot.



WARNING:
Substitute the boot and clamps when re-fitting.

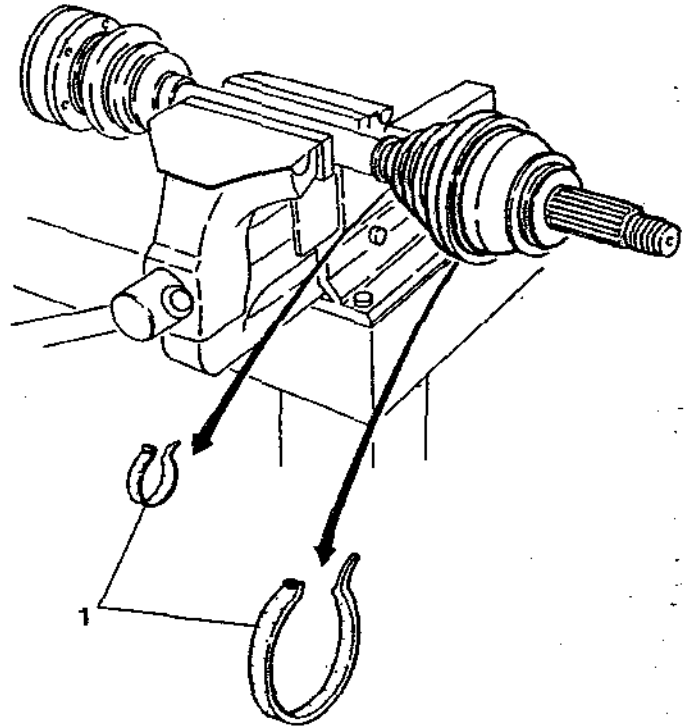

2. Remove the snap ring.
3. Using tools No. 1.821.165.000 and No. 1.821.161.000, remove the constant speed joint from the axle shaft.

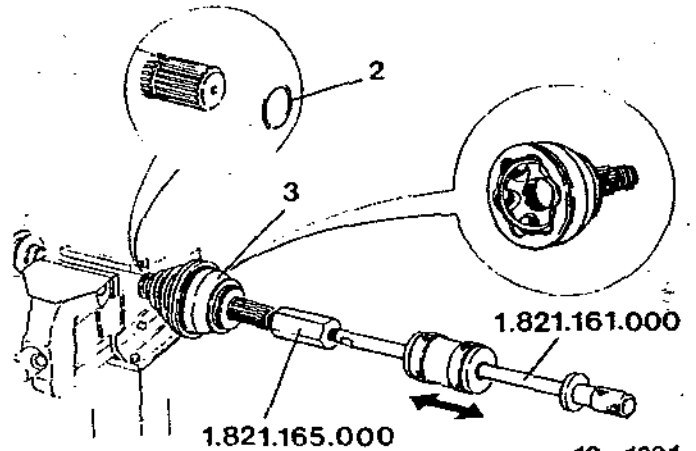



CHECKING AND ADJUSTMENT

1. Grease the components of the constant speed joint with petrol and check that the balls and seatings are not worn or cracked.
2. Check that the shaft is not deformed, cracked or worn.

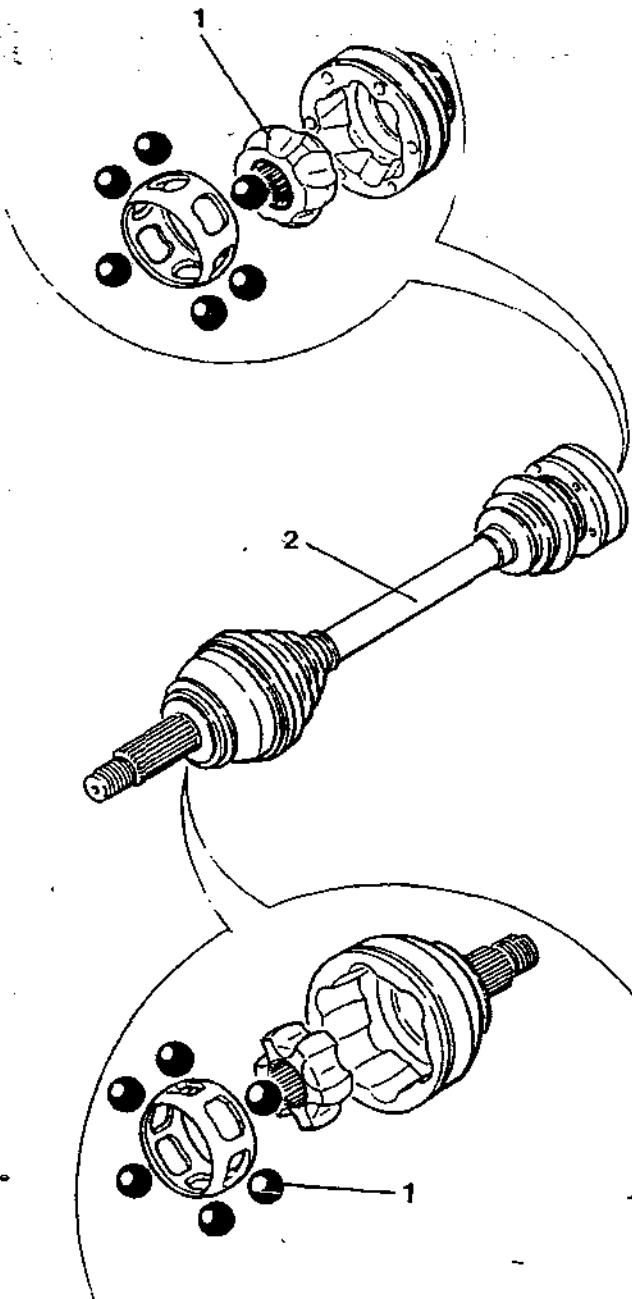

REFITTING THE JOINT ON THE WHEEL SIDE

1. Slide a new boot onto the axle shaft.
2. Position the snap ring in its seating.
3. Compress the snap ring using the securing clamp.

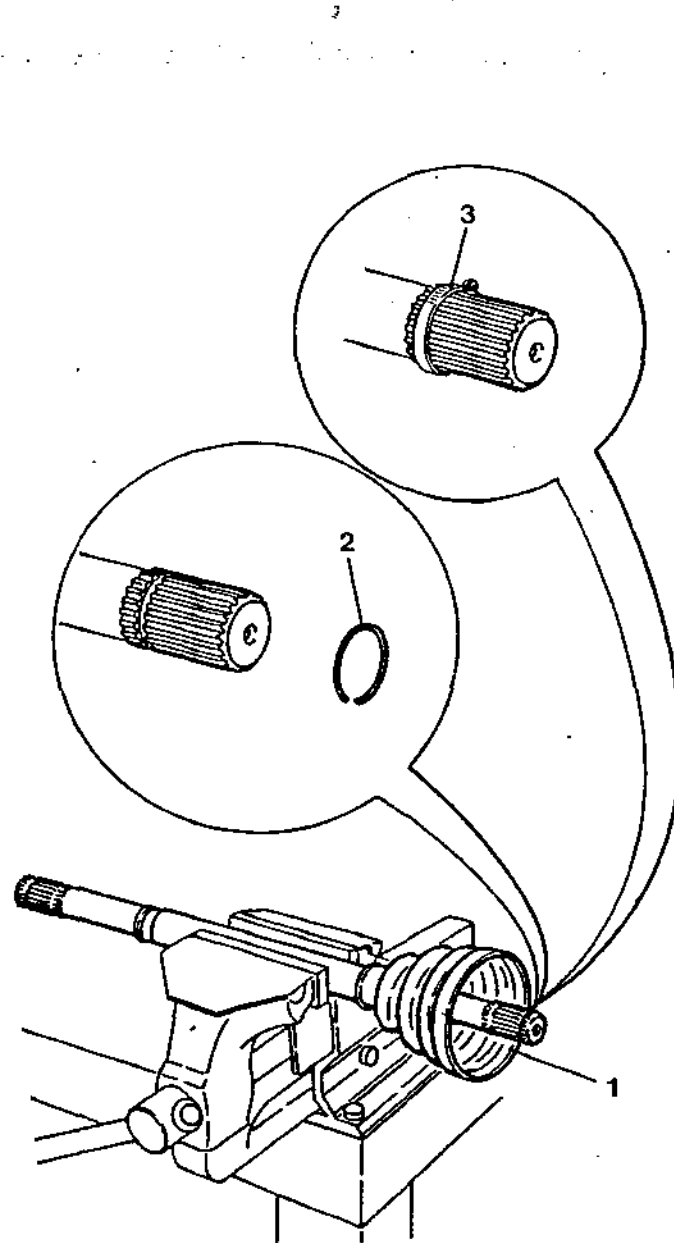



Position the constant speed joint on the axle shaft and using a soft mallet, drive it home.



Fill the boot and grease the joint with about 120 g of the specified grease.

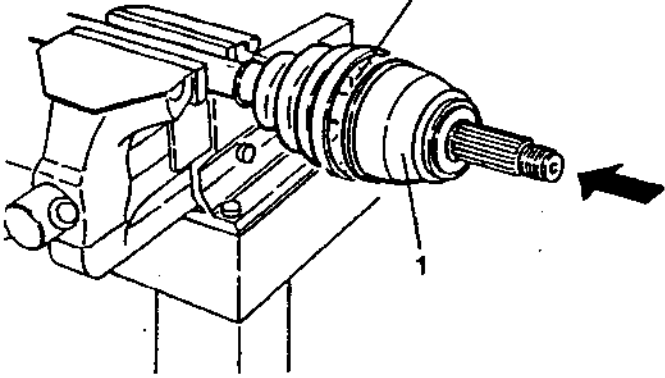

1. Using tool No. 1.820.082.000 slide the internal clamp on to secure the boot.

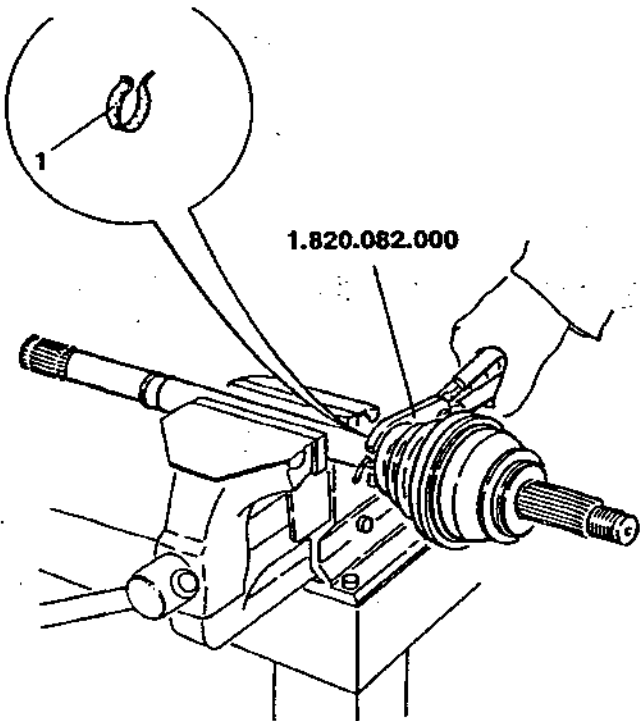

1. Using tool No. 1.820.084.000 slide the external clamp on to secure the boot.

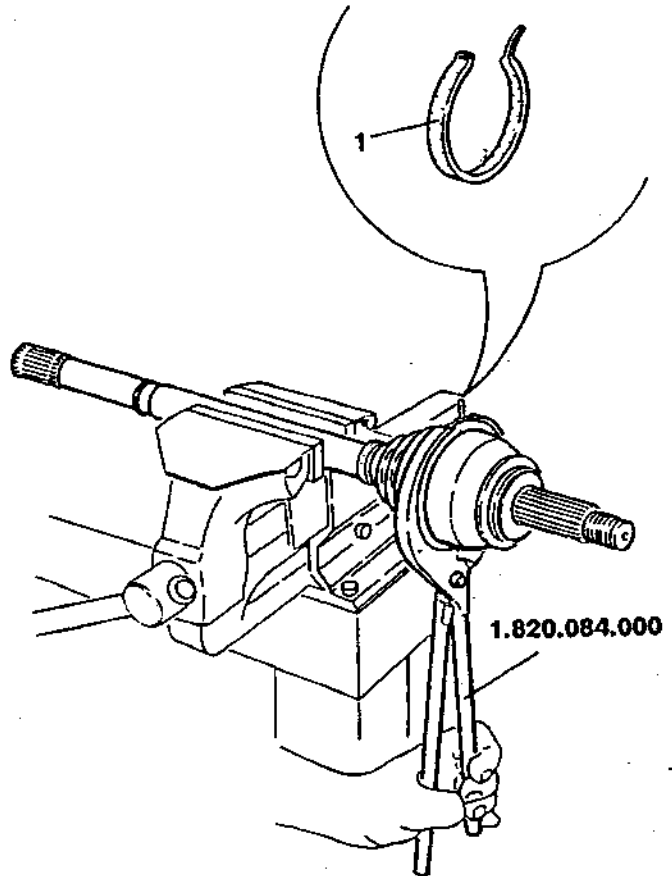



REFITTING THE JOINT ON THE GEARBOX SIDE

1. Slide a new protective boot onto the axle shaft.

**WARNING:**

Reassemble the components of the constant speed joint as shown if they have been previously removed:

A = Greatest distance between balls

B = Smallest distance between balls

Fill the boot and grease the joint with about 120 g of the specified grease.

2. Install the constant speed joint.
3. Install the snap ring.

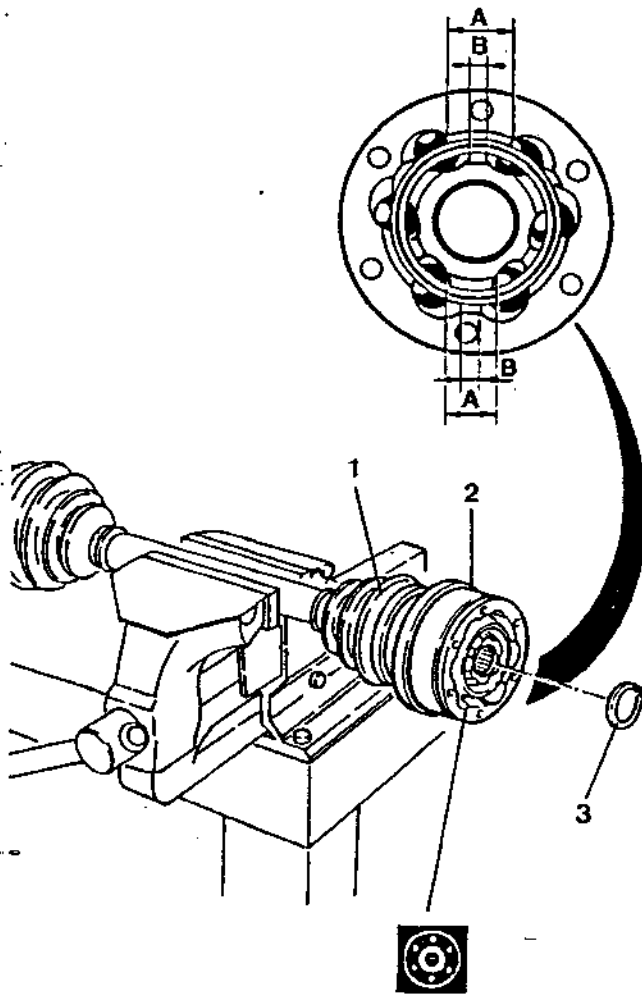

**TECHNICAL CHARACTERISTICS AND SPECIFICATIONS****GENERAL SPECIFICATIONS****FLUIDS AND LUBRICANTS**

APPLICATION	TYPE	NAME
Axle shaft constant speed joints	GREASE	OPTIMOL-OLISTAMOLY 2LN 584 MOLYKOTE VN 2461/C TUTELA MRM2

TIGHTENING TORQUES

Description	N.m	kg.m
Self-braking nuts for half-shaft retaining screws	35.7 - 44.1	3.64 - 4.49
Nut securing half-shaft to wheel hub	266 - 294	27.11 - 29.96

SPECIFIC TOOLS

TOOL NUMBER	DESCRIPTION
1.820.082.000	Pliers for installing joint protection boot clamp
1.820.084.000	Pliers for installing joint protection boot clamp
1.821.165.000	Puller for constant speed joint
1.821.161.000	Mallet (use with No. 1.821.165.000)