

155

REPAIR MANUAL

SUPPLEMENT
FOR

155

- ENGINES
- MECHANICAL UNITS
- BODY
- ELECTRICAL &
ELECTRONIC DIAGNOSIS

Alfa Romeo 

**DIVISION
OF MANUAL**

155

**REPAIR
MANUAL**

The documentation published by the Alfa Romeo Assistance Service for the "155" vehicle is composed of the following publications:

155 REPAIR MANUAL • VEHICLE CHARACTERISTICS AND MAINTENANCE	155 T.SPARK V6 - PA4655A1000000: GROUP 00
	155 ☒ - PA4655A24x4000: GROUP 00

155 REPAIR MANUAL • ENGINES	- PA4655B1000000: GROUPS 01, 04, 05, 07 Engine 1995 cm ³ (code AR 67202) Engine 1773 cm ³ (code AR 67102) Engine 1749 cm ³ (code AR 67103)
	- PA4655B2000000: GROUPS 01, 04, 05, 07 Engine 2492 cm ³ (code AR 67301)

155 REPAIR MANUAL • MECHANICAL UNITS • BODY	- PA4655C1000000: MECHANICAL UNITS
	- PA4655D1000000: Electrical components, Bodywork, Trim, Heating and Ventilation

155 REPAIR MANUAL • ELECTRICAL & ELECTRONIC DIAGNOSIS	- PA4655E1000000: Wiring diagrams and Troubleshooting
---	---

155 REPAIR MANUAL SUPPLEMENT FOR 155 ☒ • ENGINES • MECHANICAL UNITS • BODY • ELECTRICAL & ELECTRONIC DIAGNOSIS	- PA4736B14x4000: GROUPS 01, 04, 05, 07 Engine 1995 cm ³ TURBO (code AR 67203)
	- PA4736C14x4000: MECHANICAL UNITS
	- PA4736D14x4000: Electrical components, Bodywork, Trim, Heating and Ventilation
	- PA4736E14x4000: Wiring diagrams and Troubleshooting

NOTICE

This manual "155 - REPAIR MANUAL - SUPPLEMENT FOR 155 ☒ " comprises the following subjects:

- Engine
- Mechanical units
- Body
- Electrical & electronic diagnosis

The subjects relative to:

- Vehicle characteristics and maintenance
- are described also for the "155 ☒" in the volume "155 - VEHICLE CHARACTERISTICS AND MAINTENANCE.

All the information contained in this manual is accurate to the date of publication.

Alfa Romeo reserves the right to carry out any modifications to its products considered necessary without warning, though the technical information and up-dates regarding this manual will be promptly published.

NOTE:

You are reminded that within this manual, the "155 ☒" may also be referred to as "4x4 version" or "2.0 TB 4x4".

INTRODUCTION

This publication provides the information necessary for the maintenance and repair operations regarding the **155** . The aim of this publication is to provide the Alfa Romeo Service staff with a tool which can be used to rapidly identify any faults and help to render the intervention precise and efficient.

In the sections of "ENGINES", "MECHANICAL UNITS" and "BODY", the manual shows the procedures relative to the removal and refitting operations, disassembly and checks regarding the various groups which form the vehicle. The procedures are illustrated in detail as is the use of any necessary tools.

For information relative to the electrical systems of the vehicle the ELECTRICAL - ELECTRONIC DIAGNOSIS section should be consulted. This section gives the electrical diagrams and the descriptions of each function, the tables of the connectors and the location of the relative components.

Particular attention has been given to the fault diagnosis procedures which can be found at the end of each group. These combine with the irreplaceable experience of the operator and help to correctly identify and rectify the fault starting from the malfunction which the operator himself has detected and carrying out a series of tests on the system affected by the fault.

How to use this manual

(In the sections of "ENGINES", "MECHANICAL UNITS" and "BODY").

This manual is divided into chapters (GROUPS) relative to each of the assemblies which make up the vehicle.

To rapidly identify the group required, refer to the initial index.

Each group is accompanied by an analytic index and an illustrated index in order to facilitate the search for the required subject.

A brief description of the "removal/refitting", "disassembly/reassembly" and "checking and adjustment" procedures follows.





































The procedures show the complete disassembly of the components and should be carried out alone only when strictly necessary. The "reassembly" and "refitting" procedures are normally a simple reversal of the "disassembly" and "removal" procedures and only the reassembly procedures which are significantly different are illustrated.

The technical data, specific tools and fault diagnosis procedures follow the procedures mentioned above.

Symbols

This manual employs a series of symbols in order for the main technical information provided to be easily located.

The list of the symbols follows.

	removal/disassembly		
	refitting/reassembly		
	Tighten to the torque		
	Rivet nut		
	adjustment/regulation		
	visual check		
	lubricate		
	weight difference		
	angular value		
	pressure		
	temperature		
	Bleed air from brake system		
	surface to be treated		
	interference		
	play		
	intake		
			exhaust
			lubricate with engine oil
			left-hand thread
			tightening torque in oil
			engine idle speed
			ovalization
			taper
			eccentricity
			flatness
			diameter
			linear dimension
			parallelism
			top-up with grease
			heating temperature
			seal
			top-up with engine oil
			grease
			WARNING!
			CAUTION!

Indications for the operators

All the operations must be carried out with the greatest care in order to avoid damaging vehicles and persons.

- For some procedures the use of the Alfa Romeo specific tools is indicated. The use of these tools is indispensable to the safety of the operation and to avoid damage to the parts involved in the procedure.
- To detach adhering parts, lightly tap with an aluminium or lead mallet; for parts in metal and a wooden or resin mallet for parts in light alloy.
- When disassembling check that the necessary parts have been marked.
- If necessary when refitting, lubricate the parts to prevent seizing or binding during the initial stages of operation.
- Using adhesive tape or clean rags, protect the parts which, after disassembly may allow dust or foreign particles to enter the engine.
- When refitting it is vital that the tightening torques and regulation settings are respected.
- During removal substitute the seal rings, oil seals, flexible washers, safety plates, self locking nuts and any other part showing signs of wear.
- Avoid marking the fittings inside the vehicle.

Assemblies or detached parts must only be replaced by original spare parts as only in this way can the suitability of the part and its perfect operation be guaranteed.

- **CAUTION** and **WARNING** indicate those procedures which must be carried out with particular care in order to prevent personal injury or damage to the vehicles.



WARNING:

is used when lack of care may cause personal injury.



CAUTION:

is used when lack of care may cause damage to the vehicle or parts of it.

- Obey the current safety regulations regarding operation in the workshop. Where necessary specific precautions have been given in the manual in order to prevent dangerous situations from arising.

NOTE:

It is possible that some subjects have not been covered in time for publication.

In the indexes to the individual groups these subjects are indicated however and are accompanied by the words "Due for publication".

The Technical Assistance will provide documentation relative to these subjects in the form of up-date sheets or in "Technical Bulletins" which will promptly be sent to the Alfa Romeo Assistance Network.

NOTE:

It should be pointed out that inside this manual the "155" vehicle may also be indicated with the "167" vehicle code.

VEHICLE IDENTIFICATION IDENTIFICATION LABELS

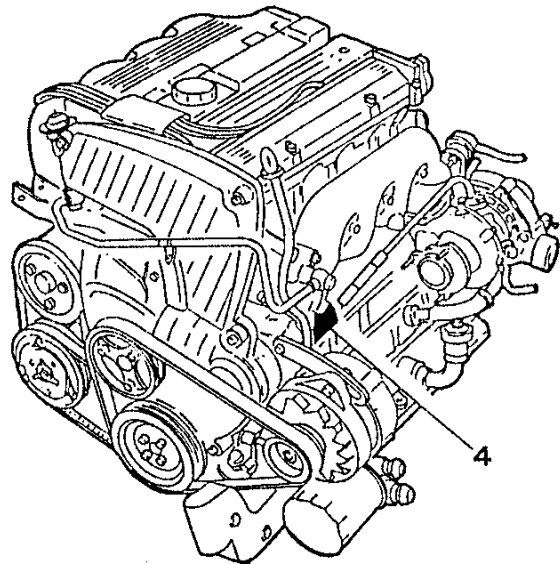
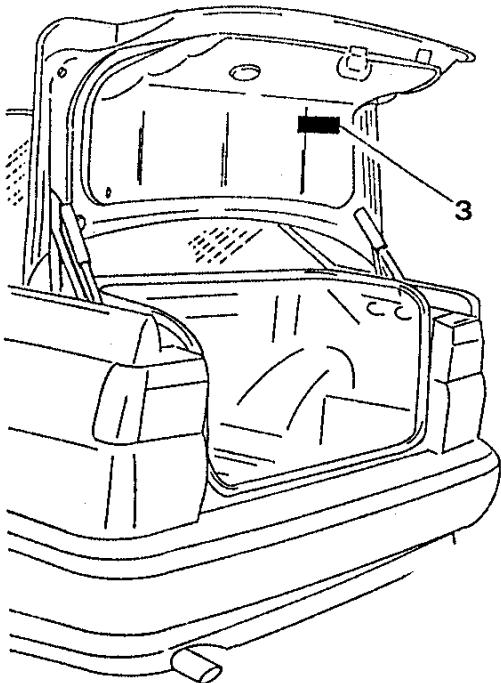
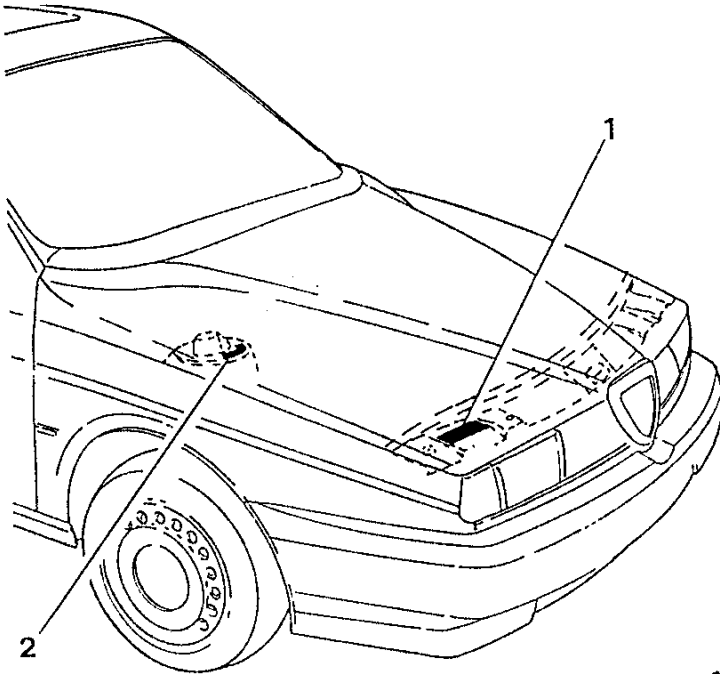

1. Label carrying identification data
2. Body label
3. Body paint identification label
4. Engine label

MODEL IDENTIFICATION

Vehicle		155 
Trim level		4-door saloon
Drive		LH + RH
Car model no.	on identification label	167A2C
	in the engine compartment, at the side of the right shock absorber upper coupling	167000
Engine type and serial no.		AR67203 from 000001

MODEL IDENTIFICATION ('95 Versions)

Vehicle		155 
Trim level		4-door saloon
Drive		LH + RH
Car model no.	on identification label	167A2E
	in the engine compartment, at the side of the right shock absorber upper coupling	167000
Engine type and serial no.		AR 67203 from (*)

(*) Engine no. not available at time of going to press



GROUP 00

VEHICLE CHARACTERISTICS AND MAINTENANCE

INDEX

DIMENSIONS.....	00 - 3		
WEIGHTS AND LOADS.....	00 - 4		
WHEELS AND TYRES.....	00 - 5		
IDENTIFYING THE MODEL.....	00 - 6		
– Identification labels.....	00 - 6		
– Identification table.....	00 - 7		
– Overall identification label.....	00 - 8		
– Body paint identification label.....	00 - 8		
DIMENSIONS ('95 Versions).....	00-8/1		
WEIGHTS AND LOADS ('95 Versions).....	00-8/2		
WHEELS AND TYRES ('95 Versions).....	00-8/2		
MODEL IDENTIFICATION ('95 Versions).....	00-8/3		
– Model identification.....	00-8/3		
– Identification label.....	00-8/3		
SPECIFIC TOOLS.....	00 - 9		
LIFTING AND TOWING POINTS.....	00 - 9		
SERVICING OPERATIONS.....	00-11		
– Programmed checks and maintenance.....	00-14		
FLUIDS AND LUBRICANTS.....	00-15		
APPROXIMATE SERVICING CAPACITIES.....	00-18		
SPECIFIED FUEL.....	00-18		
ENGINE MAINTENANCE OPERATIONS.....	00-19		
		– Replacing engine oil and filter.....	00-19
		– Checking and adjusting valve clearance.....	00-20
		– Replacing timing belt.....	00-23
		– Auxiliary unit belts.....	00-36
		– Water pump alternator drive belt.....	00-37
		– Air conditioning compressor drive belt.....	00-39
		– Power steering pump drive belt.....	00-43
		– Checking pressure and sealing of fuel circuit.....	00-48
		– Checking sealing of the fuel vapour recovery system (due for publication).....	00-50
		– Replacing air cleaner cartridge.....	00-50
		– Checking sealing of air supply system and over-boost valve control circuit (due for publication).....	00-51
		– Checking sealing of blow-by system (due for publication).....	00-51
		– Replacing fuel filter.....	00-52
		– Checking and regulation of idle speed.....	00-53
		– Checking operation of the lambda probe.....	00-53
		– Checking exhaust emissions.....	00-54



- Checking ignition advance 00-56
- Checking and replacing spark plugs 00-57
 - Maintenance 00-57
- Checking the seal on the engine cooling system pressurized cap 00-58
- Checking the sealing of the engine cooling system 00-58
- Checking level and replacing engine coolant 00-59
- MAINTENANCE OF MECHANICAL UNITS. 00-61**
 - Checking for damage of the half-shafts, power steering bellows, steering knuckle covers and drive shaft. 00-61
 - Drive half-shafts 00-61
 - Steering rod 00-61
 - Drive shaft 00-62
 - Checking sealing of braking system 00-63
 - Checking level of clutch/brake fluid. 00-64
 - Checking handbrake travel 00-64
 - Checking power steering fluid 00-65

- Checking level and replacing gearbox and front differentials oil . . . 00-65
- Checking and replacing rear differential oil. 00-67
- Lubricating the door, bonnet and boot hinges and bonnet/boots catches devices 00-68
 - Doors 00-68
 - Bonnet 00-68
 - Boot 00-68

TECHNICAL CHARACTERISTICS AND SPECIFICATIONS 00-69

- Belt tensioning 00-69
- Valve clearance. 00-69
- Checking fuel supply pressure 00-69
- Checking idle speed 00-70
- Checking exhaust emissions 00-70
- Ignition 00-70
- Cooling system 00-70
- Handbrake 00-70
- Filling with fluids and lubricants. 00-71
- Tightening torques 00-72
- SPECIFIC TOOLS. 00-73**



DIMENSIONS ('95 Versions)

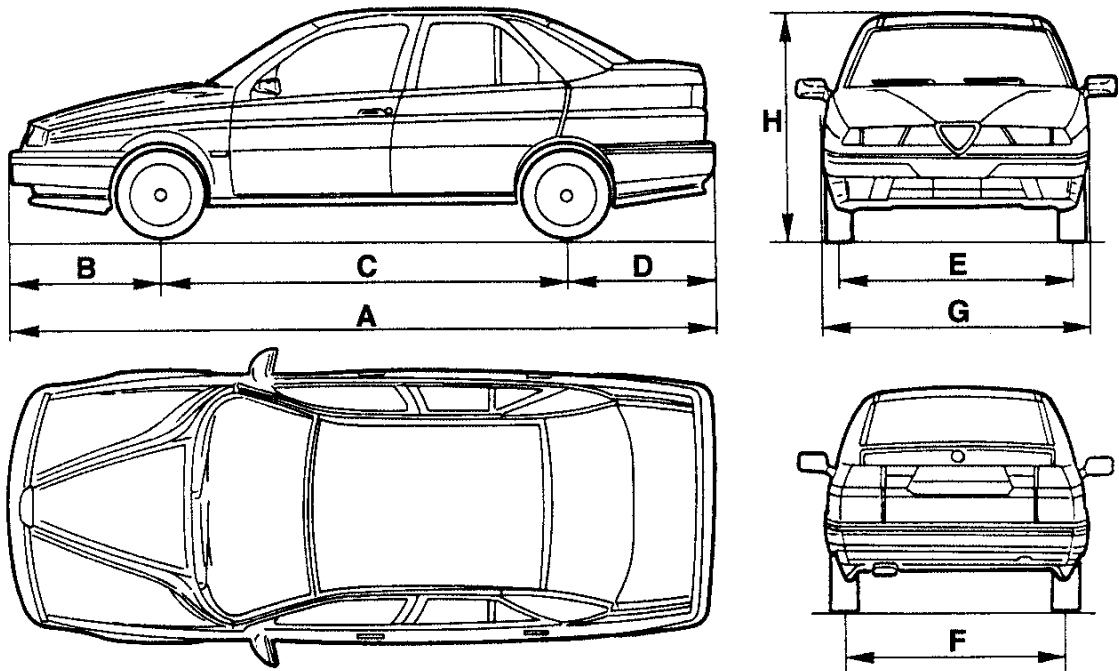

Version		155	
		(167A2E)	
Dimensions			
A	Maximum length	mm	4443
B	Front overhang	mm	960
C	Wheelbase	mm	2540
D	Rear overhang	mm	943
E	Front track	mm	(*)
F	Rear track	mm	(*)
G	Maximum width	mm	1730
H	Maximum height	mm	(*)

(*): Not available at time of going to press.

**WEIGHTS AND LOADS ('95 Versions)**

		Version	155
			(167A2E)
Weights and loads			
Kerb weight (without driver)		kg	1465
Towable weight	(with brakes trailer)	kg	1500

WHEELS AND TYRES ('95 Versions)

		Version	155
			(167A2E)
Specifications			
Rim size			7J x 16" (▲)
Tyre size	standard		205/45 ZR16
	optional (for versions/markets, where applicable)		205/50 ZR15
Tyre pressure bar - kg/cm ²	reduced load (2 persons)		front 2.5 rear 2.3
	full load		front 2.8 rear 2.5
Compact spare wheel	rim size		4B x 15" (in alloy)
	tyre size		115/70 R15 90M
	tyre pressure bar - kg/cm ²		4.2

(▲): 6.5J x 15" with 205/50 ZR15 tyres

WARNING:

In the event of continuous driving at top speed, the pressures should be increased by 0.3 bar.

NOTE: To improve mating between the wheels and the car body, the rims have a specific camber for each rim size. Therefore, in addition to the correct rim and tyre match it is also necessary to check and maintain the rim camber angle.

RIM SIZE	RIM CAMBER ANGLE
6.5J x 15"	37 mm
7J x 16"	41 mm

**MODEL IDENTIFICATION ('95 Versions)****MODEL IDENTIFICATION**

Vehicle		155
Trim level		4-door saloon
Drive		LH + RH
Model no.	on identification label	167A2E
	in the engine compartment, at the side of the right shock absorber upper coupling	167000
Chassis serial number		(*)
Engine type and serial number		AR 67203 from (*)

(*) engine/chassis no. not available at time of going to press.

IDENTIFICATION LABEL

	(F)	
	(A)	
	(B)	
	(C)	
	(C)	
	1 - (C)	
2 - (C)		
(E)	MOTORE - ENGINE (D)	
	VERSIONE - VERSION (D)	
	N° PER RICAMBI N° FOR SPARES (D)	

- A. National homologation number
- B. Chassis serial number
- C. Space available for maximum weights authorized by the different national regulations
- D. Space reserved for version (for example 167A2E) and any supplementary information
- E. Smoke opacity index
- F. Name of manufacturer



SERVICING OPERATIONS

The servicing operations comprise checking and restoring the efficiency of certain parts of the vehicle on which wear and phase displacement are foreseen after normal use.

The following table lists the servicing operations to be carried out at the specified mileage intervals.

WARNINGS:

Precautions to be taken before servicing operations. The engine compartment contains many moving parts, high temperature components and high voltage cables that can be dangerous.

Carefully follow the precautions given below:

- Turn the engine off and allow it to cool down.
- Do not smoke or use naked flames. The presence of fuel can cause a fire hazard.
- Always keep a fire extinguisher handy.

Operations to have done at the mileage shown	km x 1,000									
	20	40	60	80	100	120	140	160	180	200
Changing the engine oil and filter (at all events once a year) and checking lubrication circuit for leaks	Every 10,000 km									
Checking valve clearance (except engines with hydraulic tappets)		●		●		●		●		●
Changing the timing gear drive belt						●				
Checking the conditions of the trapezoidal belts		●		●		●		●		●
Checking the conditions of the Poly V belts				●				●		
Changing the air cleaner cartridge		●		●		●		●		●
Changing the fuel filter cartridge (petrol versions)				●				●		
Checking operation of the exhaust gas oxygen sensor (lambda probe)				●				●		
Changing the spark plugs	●	●	●	●	●	●	●	●	●	●
Changing the anti-freeze mixture				●				●		
Checking the gearbox and differential oil level (only versions with manual gearbox)				●				●		
Checking conditions of protective bellows for axle shafts, power steering and steering knuckle caps		●		●		●		●		●
Checking brake and fuel system pipes for leaks		●		●		●		●		●
Checking handbrake travel		●		●		●		●		●
Checking power steering oil level		●		●		●		●		●



SERVICING OPERATIONS (Continued)

To keep the car in good operating conditions, the following recommendations should be adhered to carefully:

Every 500 kms (or when refuelling) check:

- the engine oil level.
- the level of the fluid in the coolant circuit.
- the level of the brake/clutch fluid.
- the tyre pressures.
- the level of the fluid in the windscreen wiper/washer system.

Engine oil and filter

To be changed at the specified intervals.

At all events, they must be changed once a year.

Air cleaner

If the car is habitually used on dusty roads, the air cleaner should be changed more often than specified.

Brake pads

Wear of the brake pads is indicated by the turning on of a warning light on the instrument cluster.

When changing the front pads, also check the rear ones. However, depending on the use of the car, the rear pads might not need to be changed immediately, in which case, you are recommended to check them at a later stage.

Brake and clutch fluid

The brake fluid is hygroscopic, i.e. it absorbs moisture.

To avoid faulty braking, change the brake fluid every two years, regardless of the mileage driven.

Battery

During hot weather, check the electrolyte level frequently.

Dust and/or pollen filter (if fitted)

Once a year, preferably at the beginning of summer, have the conditions of the dust and/or pollen filter (if fitted) checked by the Alfa Romeo Service Network.

If the car is mostly used for town/motorway driving or on dusty roads, it is wise to check more often than indicated.

Warning: Failure to change the filter can considerably reduce the performance of the air conditioner system.

Anti-freeze

It is advisable to top up with **Alfa Romeo Climafluid Super Permanent -40°C** to conserve the protective properties of the mixture.

Notes

Under special driving conditions (e.g. on roads sprinkled with antifreeze salt and/or corrosive substances, rough road surfaces, etc.) often check the boots of the axle shafts and steering box, and clean and lubricate joints, hinges, door catches, bonnet catch, etc.)

When forced to use fuel, lubricants and/or fluids in general with characteristics other than those specified by the manufacturer (in emergencies), replace the fluids and corresponding filters at the earliest opportunity.



PROGRAMMED CHECKS AND MAINTENANCE

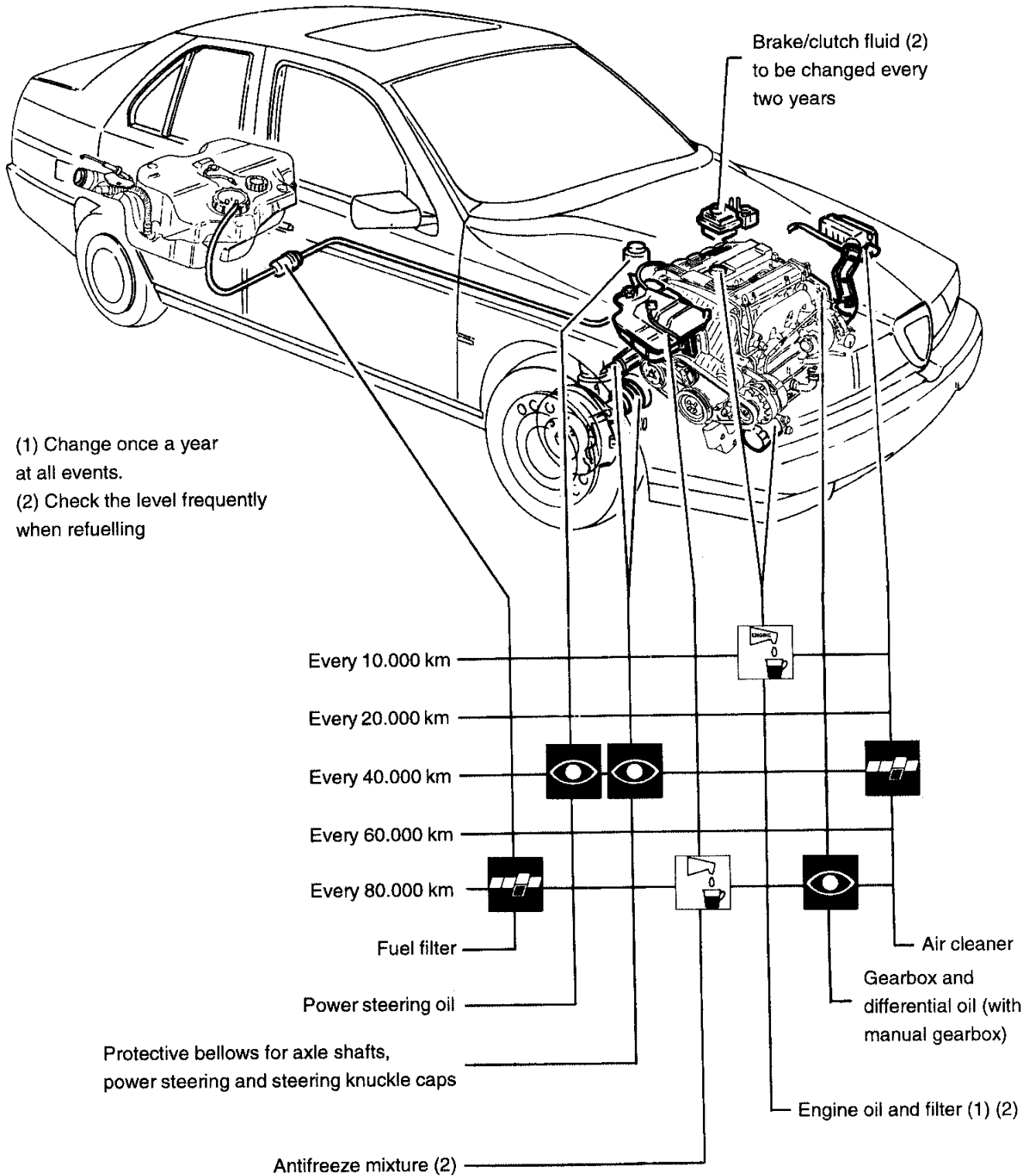



(*): This page replaces pages 00-15/16/17
of publication PA4655A24x4000 of 12 - 1991.
Therefore pages 00-16/17 are deleted

FLUIDS AND LUBRICANTS

Type	Group ref.	Application	Classification	Name
OIL	01 - Engine (1)	Engine (Refilling)	API SG CCMC G5 SAE 10W/40	SELENIA SPECIAL FORMULA ALFA ROMEO 10W/40
	13 - Gearbox and differential	Gearbox and differential (Refilling)	API GL-4	TUTELA ZC 80/S
	18 - Rear axle 4-wheel drive	Rear axle (Refilling)	SAE 80W/90 API GL-5	TUTELA W90/M - DA
	80 - Climate control	Compressor (Refilling)	-	SUNISO 5GS SANDEN SP 10 "PAG" (▲)
FLUIDO	07 - Engine cooling	Cooling circuit (Refilling)	-	ALFA ROMEO CLIMAFLUID SUPER PERMANENT -40°C
	12 - Clutch	Brake & clutch hydraulic circuit (Refilling)	DOT 4	ALFA ROMEO BRAKE FLUID SUPER DOT 4
	22 - Brakes		SAE J 1703 F	
	23 - Steering	Power steering system (Refilling)	G.M. DEXRON II	TUTELA GI/A
80 - Climate control	Conditioning system circuit (Refilling)	-	RIVOIRA Freon 12 - RIVOIRA: SUVA R134a (▲) - HOECHST - TAZZETTI: FRIGEN R134a (▲) - ICI - TAZZETTI: KLEA R134a (▲)	
GREASE	SEE SPECIFIC FUNCTIONAL GROUPS			

(1): For decidedly sportive use of the car fully synthetic **SELENIA Racing 10W/60** engine oil is recommended
(▲): From chassis no. 105779 - 1003349 (on two assembly lines).

**APPROXIMATE SERVICING CAPACITIES**

Capacity		Version	155
Fuel tank			60 litres
Fuel reserve			~ 5 litres
Engine oil	Total capacity: sump + filter + wells + radiator		5.5 litres
	Sump + filter (for periodical replacement)		4.5 litres
	Oil filter		0.4 litres
	Camshaft wells + oil radiator		1.0 litres
Oil for gearbox - front differential and central converter			4 litres
Rear differential oil			1.4 litres
Brake - clutch circuit fluid			0.6 litres
Power steering system oil			1.0 litres
Antifreeze mixture			9.1 litres
Conditioner compressor oil			135 g 240 ± 15 cm ³ (▲)
Conditioning system fluid			950 g 700 g (▲)

(▲): From chassis no. 105779 - 1003349 (on two assembly lines).

SPECIFIED FUEL

The octane number of a fuel defines its resistance to detonation: it is essential to use fuel with the correct number of octanes as this will prevent pinging which may prove dangerous for the engine.

The higher the octane number the greater the anti-detonation capacity.

The 155 model has been designed to run on unleaded petrol with an octane number of 95 RON (Research Octane Number).

These vehicles are all fitted with a catalytic converter. To enable this to function with the highest degree of efficiency, unleaded petrol must be used, as the lead deposits contained in other fuels build up on the surface of the catalytic converter and prevent it from working properly. The size of the filler necks has been reduced in order to prevent the nozzles used on leaded petrol pumps from being inserted.



FILLING WITH FLUIDS AND LUBRICANTS

See "FLUIDS AND LUBRICANTS" PAGE 00-15 and "APPROXIMATE SERVICING CAPACITIES" page 00-18.

**TIGHTENING TORQUES****ENGINE**

Part	Nm	kgm
Oil sump drain plug	32.5 + 52.5	3.3 + 5.4
Spark plugs	23 + 28.4	2.3 + 2.9
Water pump pulley fastening screw	21.3 + 26.3	2.2 + 2.7
Nut fastening timing belt guide pulley	37.4 + 46.2	3.8 + 4.7
Nut fastening counter-rotating shafts belt guide pulley	19.5 + 24.2	2.0 + 2.5
Fuel inlet union in filter	30 + 37	3.1 + 3.8
Fuel outlet union from filter	21 + 26	2.1 + 2.7

GEARBOX AND DIFFERENTIAL

Part	Nm	kgm
Threaded cap for filling gearbox oil	35 + 55	3.56 + 5.6
Magnetic plug on gearbox for draining oil	19 + 30	1.94 + 3.06
Union for swivel fitting fastening oil delivery pipe to bevel pinion support	29.75 + 36.75	3.03 + 3.75

REAR DIFFERENTIAL

Part	Nm	kgm
Threaded oil filler cap	29.9 + 48.3	3.04 + 4.92
Threaded oil drain cap	29.9 + 48.3	3.04 + 4.92